

Test Report

No. 14-003899-PR04
(PB-E01-02-en-01)



Date of report 30.04.2015

Client ROLKA A.B.E.E.
3 KM P.E.O. Katerinhs
Thessalonikis T.TH. 148
60100 Korinos Pierias
Greece

Order Test of resistance to wind load under dynamic
wind load

Object Roller shutter with built-in box, inspection from inside and
foamed aluminium laths

Type: RS POL839

Contents	1	Object
	2	Procedure
	3	Results
	4	Evaluation
	5	Notes on publication of ift test documents

1 Object

1.1 Description of test specimen type RS POL839

Manufacturer	ROLKA A.B.E.E.
Designation	RS POL839
	built-in roller shutter with manual operation
Element size (W X H)	1,400 mm x 2,400 mm
Slatted roller blind housing	
Material	aluminium, white coated
Dimensions (D x H)	182 mm x 182 mm
Inspection opening	inside at front
Shutter curtains	
Material	aluminium, white coated, PU foamed
Item No.	lath: 8-939
	bottom lath: KAT - 001 with gasket IXO - 000
Wall thickness	0.20 mm
Number of bars	56, on sides secured against displacement
Profile cross section (W x T)	lath: 44,5 mm x 8 mm
	bottom lath: 45 mm x 7 mm
Edge cover of curtain in guide grooves	2 x 20.5 mm
Clearance of curtain in guide grooves	2 x 6.2 mm
Dimensions	
Lath width	1326 mm
Visible size of curtain (W x H)	1,296 mm x 2,200 mm
Guide rail	53 mm x 22 mm
Material	aluminium, white coated
Item No.	KAN - 001
Guide groove (D x W)	26.7 mm x 20.2 mm
Silencing gasket	brush on both sides, 6.9 mm x 6 mm
Fixing method	bolted all 600 mm
Drive	belt drive
Exit position	horizontal at top (position 4 as per EN 13527)
Reduction ratio	1 : 5
Lever arm operation	--

The description is based on inspection of the test specimen at the **ift**. Item designations/ numbers as well as material specifications were given by the client. The above specifications and details are retained with the testing body.

1.2 Representation of test specimen

The constructional details were tested solely for the characteristics to be verified. The photographs were taken at the ift during testing. The drawings are based on unchanged documentation provided by the client.

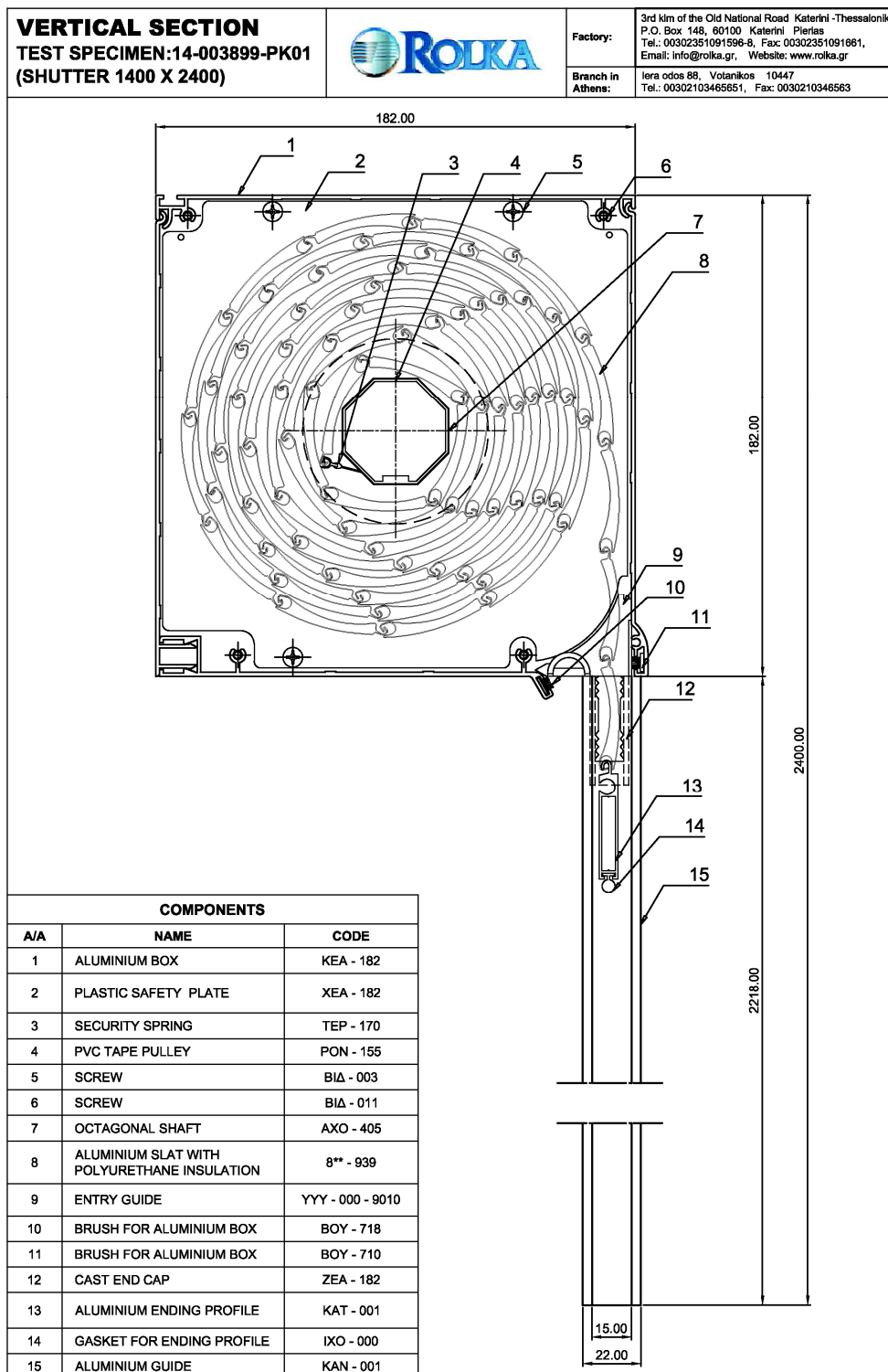

Figure 1 Vertical section

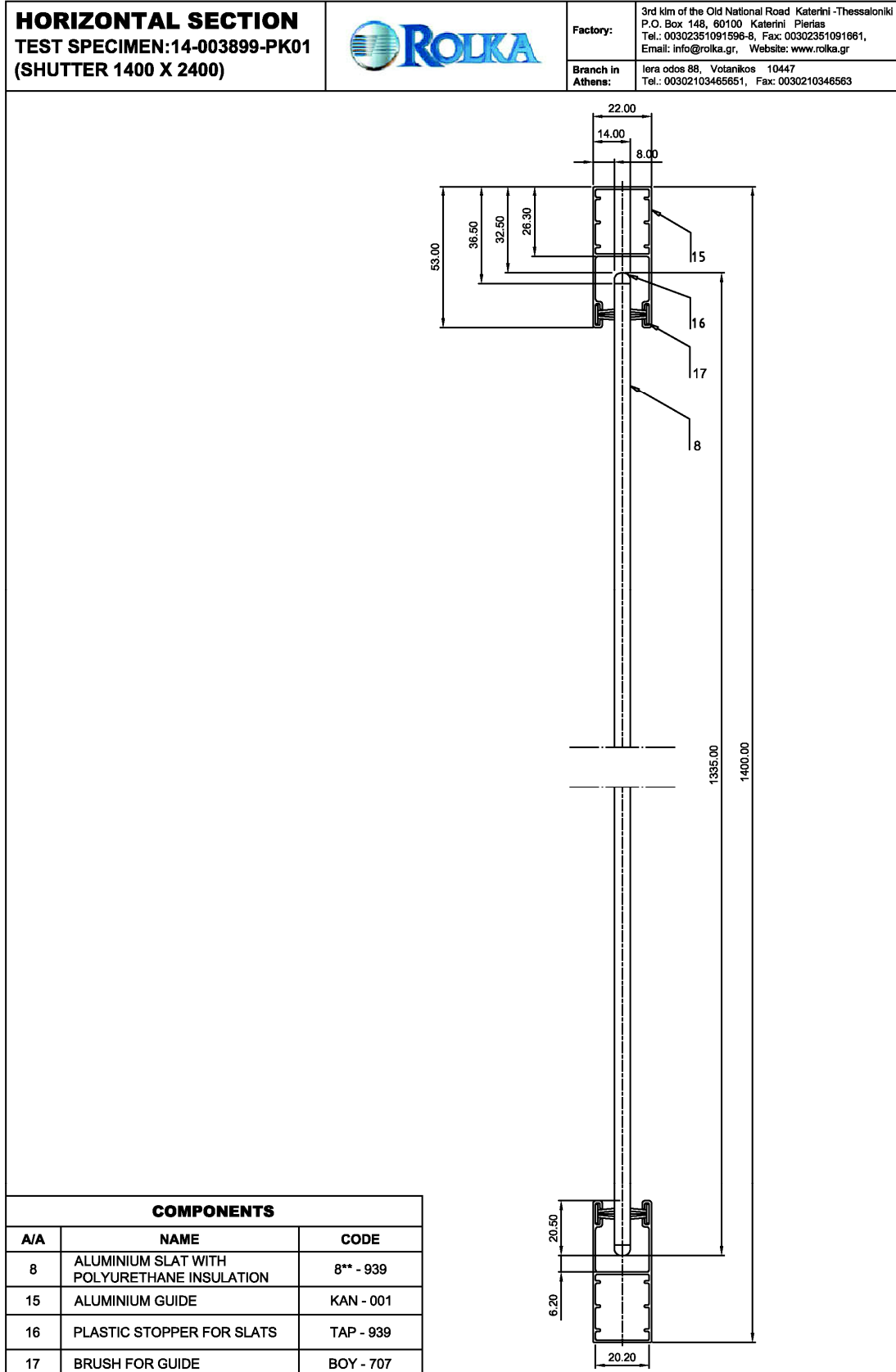

Figure 2 Horizontal section



Figure 3 Test specimen



Figure 4 Bottom lath and guide rail



Figure 5 Detail bottom lath



Figure 6 Details of lath profile



Figure 7 Details of lath profile with slider



Figure 8 Roller shutter box

2 Procedure

2.1 Sampling

The test specimens were selected by the client:

Number	1
Delivered on	24 February 2015 by the client
Specimen registration No.	WE 38762/004
Date of manufacture	February 2015

2.2 Test equipment

Wind generator 1	Device No.: 22209
Wind generator 2	Device No.: 22210
Vane anemometer	Type TESTO 452 combined metering device: Speed range. 0.4 to 60 m/s Device No.: 22596

2.3 Testing

The test was witnessed by

Date/Period	24 February 2015
Attended by	Mr. Gkekas Mr. Papakostas
Test engineer	Dipl.-Ing. (FH) Thomas Stefan

2.4 Description of dynamic wind load test

The test specimen was exposed to dynamic wind load provided by two wind generators (rotor diameter \varnothing 1 m) arranged one above the other. The wind load was adjusted by setting the speed of the wind generators to different wind velocities, see Table 1.

Table 1 Wind velocities measured at a distance of approx. 1 m in front of roller shutter

Measuring position	Wind speed in m/s	Wind speed in km/h	Wind speed Wind force in Bft
1	15.0	54	7
1	20.0	72	8
1	25.0	90	10
1	28.0	101	10
1	32.0	115	11

The wind speeds generated were measured approx. 1.0 m respectively approx. 2.33 m above ground using a vane anemometer located at a distance of 1 m in front of the test specimen. The distance between the wind generators and the test specimen was 4.0 m.

2.5 Test sequence

The roller shutters were extended and retracted before application of the wind loads. The wind load was applied to the extended roller shutter. After completion of the wind load test an operational test was conducted with the roller shutter being extended and retracted again. This was followed by visual inspection of the test specimen.

The tests were performed in the sequence described in Table 2:

Table 2 Test sequence

No.	Wind speed in m/s	Duration	Test sequence
1	0	<i>Operational test prior to testing</i>	
2	15.0	5 min	Extended position, measurement of maximum central deflection
3	0	<i>Operational test Visual inspection/assessment for occurrence of any damage</i>	
4	20.0	5 min	Extended position, measurement of maximum central deflection
5	0	<i>Operational test Visual inspection/assessment for occurrence of any damage</i>	
6	25.0	5 min	Extended position, measurement of maximum central deflection
7	0	<i>Operational test Visual inspection/assessment for occurrence of any damage</i>	
8	28.0	5 min	Extended position, measurement of maximum central deflection
9	0	<i>Operational test Visual inspection/assessment for occurrence of any damage</i>	
10	32.0	5 min	Extended position, measurement of maximum central deflection
11	0	<i>After completion of the wind load test an operational test was conducted with the roller shutter being retracted and extended once again. This was followed by visual inspection of the test specimen.</i>	

Figures 9 to 12 show the schematic test arrangement and the measurement points.



Figure 9 Test wall

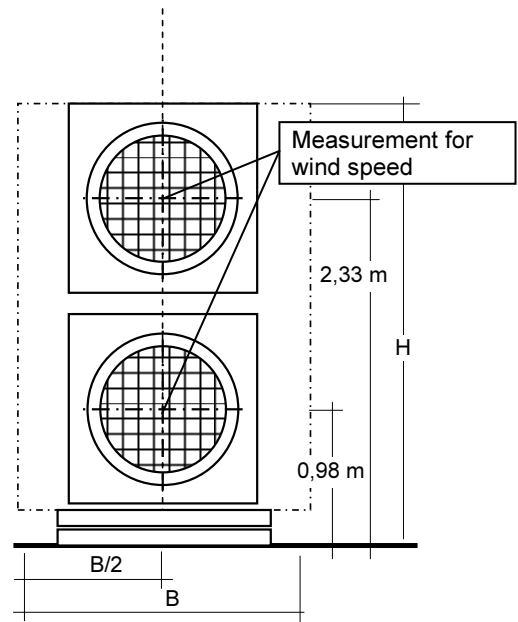

Figure 10 Position of wind generators



Figure 11 Layout of wind generators

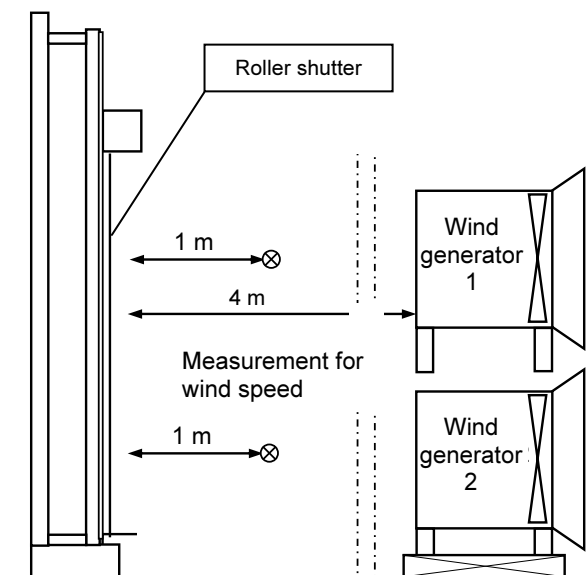

Figure 12 Test configuration for dynamic wind load

3 Results of dynamic wind load test

Test under dynamic wind load, ift In-house method Roller shutter

Project No.	14-003899-PR04
Client / contact	ROLKA A.B.E.E.
Element	Roller shutter
Manufacture of test specimen	February 2015
Delivery of test specimen	24.02.2015
Date of test	24.02.2015
Attended by	Mr. Gkekas, Mr. Papakostas

System	RS POL839		
Lamella	Aluminium foamed		
Element size	1400	x	2400 mm
Clear	1296	x	2200 mm
lath dimensions	44,5	x	1326 mm

Specimen No.	38762/004
Test engineer	Thomas Stefan

Temperature	20,4 °C
Air humidity	40,4 %

Seen from outside

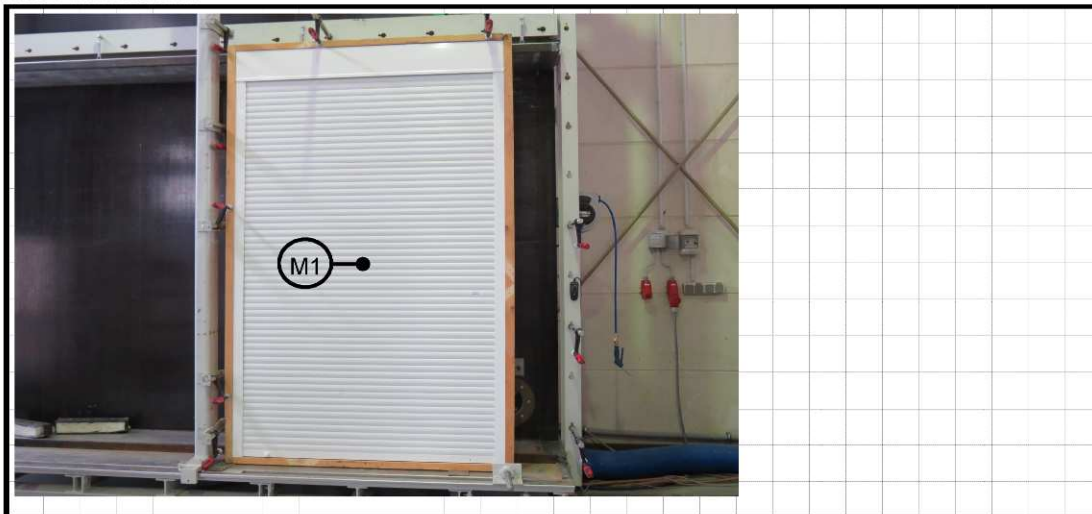

Photo 1 Test specimen

Key

 Measurement point of deflection

Test record, dynamic wind load

1. Roller shutter closed

Specimen No. WE 38762/004

Wind load wind pressuer, holding time each pressure step 5 minutes

Fan space to test specimen: 4 m

Curtain moved to right

Wind speed *)		Deflection mm	Observations
15.0 m/s	54 km/h	31	slight oscilatingof top cover, slight deflection of curtain
after load		0	Operational test OK
20.0 m/s	72 km/h	58	slight deflection of curtain, oscilatingof top cover, slight deflection of bottom lath
after load		0	Operational test OK
25.0 m/s	90 km/h	87	slight deflection of curtain, oscilatingof top cover, slight deflection of bottom lath
after load		0	Operational test OK
28.0 m/s	101 km/h	104	slight deflection of curtain, oscilatingof top cover, slight deflection of bottom lath
after load		0	Operational test OK
32.0 m/s	115 km/h	140	slip of at lower third
after load		0	defect

*) Measurement at 1 m distance from unit in centre of unit (variation approx. ± 1 m/s)

4 Evaluation

The measured results were obtained from the product in new condition. Thus they do not include any changes that are likely to be caused by the effects of weathering and/or ageing. The values mentioned in this test report refer solely to the objects described and tested under Section 1.

The test results obtained may be extrapolated for units of identical or smaller dimensions of the same design provided that consistent quality of workmanship is guaranteed by suitable control measures, and the material used as well as the make/details comply with the description of the present test report.

Table 3 can be used to analyse the test results.

Table 3 Wind speed table in Beaufort

Beaufort scale/ number	Description	Average wind speeds 10 m above open ground		Typical effects of wind over inland areas
		m/s	km/h	
0	Calm	0 – 0.2	< 1	Smoke rises vertically
1	Light air	0.3 – 1.4	1 - 5	Direction of wind shown by smoke drift
2	Light breeze	1.5 – 3.4	6 - 12	Wind felt on face; leaves rustle and wind vanes begin to move
3	Gentle breeze gentle wind	3.5 – 5.4	13 – 19	Small twigs in constant motion; light flags extended
4	Moderate breeze Moderate wind	5.5 – 7.4	20 – 27	Twigs and small branches are moved, wind raises dust and loose paper
5	Fresh breeze Fresh wind	7.5 – 10.4	28 – 37	Small trees in leaf begin to sway, crested wavelets form on inland waters
6	Strong breeze	10.5 – 13.4	38 – 48	Large branches in motion; umbrellas used with difficulty; whistling heard in telegraph wires
7	Near gale	13.5 – 17.4	49 – 62	Inconvenience felt when walking against the wind; whole trees in motion;
8	Gale	17.5 – 20.4	63 – 73	Twigs break off trees; wind generally impedes progress on foot
9	Strong gale	20.5 – 24.4	74 – 87	Branches break off trees, slight structural damage (slates and chimney pots removed from the roofs)
10	Storm	24.5 – 28.4	88 – 102	Wind breaks off trees, considerable structural damage
11	Violent storm	28.5 – 32.4	103 – 117	Trees uprooted, widespread damage
12	Hurricane	above 32.5	above 118	Devastation



5 Notes on publication of ift test documents

The enclosed **ift** Guidance Sheet "Conditions and Guidance for the Use of **ift** Test Document" sets out the rules for using the test reports.

ift Rosenheim

30.04.2015

A handwritten signature in blue ink, appearing to read 'Peter Marquardt'.

Peter Marquardt, Dipl.-Ing. (FH)
Deputy Head of Testing Department
Construction Product Testing

A handwritten signature in blue ink, appearing to read 'Thomas Stefan'.

Thomas Stefan, Dipl.-Ing. (FH)
Operating Testing Officer
Construction Product Testing